

Instruction Manual of Laser Ranging Sensor

XKC-KL200-PUB

table of contents

1st. Overview	2
2nd. Product Features	2
3rd. Scope of application	2
4th. Technical Parameters	2
5th. product selection	4
6th. Laser switch LED indicator	5
7th. wiring diagram of various models	5
8th. Sensing distance adjustment	8
9th. Dimensions and physical objects	9
10th. installation method	9
10th. Distance and Object Size Relationship	10
12th. letter of agreement	10
13th. Troubleshooting guide	16
14th. Precautions for use	16
15th. Product warranty terms and instructions	17
16th. Manual version	18

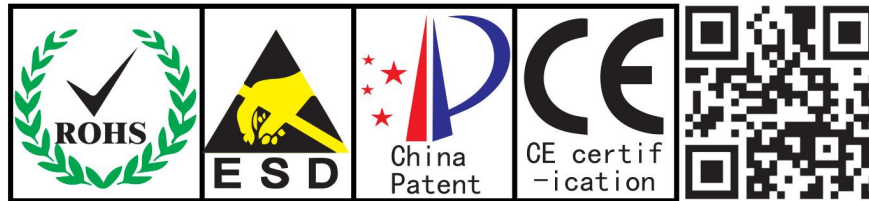

1st. Overview

XKC-KL200 is a smart non-contact switch, laser ranging sensor with UART serial port, high and low level or NPN drive output. The sensor uses the principle of laser diffuse reflection on objects: when a person or an object enters the sensing area set by the sensor, the sensor outputs a signal and can accurately output the distance; when the person or object leaves the sensing area, the sensor turns off the output.

2nd. Product Features

1. Strong anti-interference ability.
2. Intelligent induction non-contact switch, safe and hygienic.
3. The sensing angle is small.
4. Small size, easy to install.
5. A variety of output methods, easy to use.
6. Not affected by the surface color of the object.
7. In an indoor environment, the real-time measurement distance can reach 2 meters.
8. Multi-layer filter cover, the sensor is more stable.

3rd. Scope of application

1. Intelligent induction sanitary ware.
2. Home security.
3. Intelligent detection and intelligent control.
4. Robot obstacle recognition.
5. Real-time display of distance.
6. Faucet sensor, automatic flushing of toilet and toilet, automatic hand dryer, anti-theft device, automatic doorbell, stairway sensor, TV close-up TV reminder, automatic door, advertising light box, automatic trash can.

4th. Technical Parameters

project name	Parameters
Operating Voltage	DC 5~24V
Sensing distance	In the effective distance (10mm~2000mm), calibration test in various modes, various performance should meet the requirements, and the distance of 1000mm can be measured in the sun.
Sensing accuracy	±4% (Within 10mm~2000mm)
wavelength	940 nm Laser transmitter
Sensing angle	Transmit 35 degrees, receive 25 degrees.
Short circuit protection	When more than 1A, the output is turned off
Specification	24*24 (Main shell)
Load current	300mA

Working current	15mA
Working temperature	-20 ~ 65°C
storage temperature	-20 ~ 85°C
Line length	30cm (±10MM) (Bulk can be customized)
Material	shell: PC-V0 fireproof material
output method	UART serial port, NPN, high and low level

User Calibration Guide

The factory default response distance of the laser switch is 2000mm, and the default response distance can be specified according to user requirements.

Or users can calibrate themselves, the calibration steps are as follows:

1. Fix the sensor and set the distance between the measured object and the sensor within the effective distance (10mm~2000mm).
2. Long press the button for 3 seconds, the LED starts to flash slowly (1s/1s), indicating the start of calibration.
3. Wait for about 3 seconds, the calibration will automatically enter the action state after the calibration is completed, and the LED will always be on, indicating that the calibration is successful.
4. If the calibration distance exceeds the range 10-2000mm), it will flash quickly (50ms/50ms) for 2 seconds and then go out.
5. If an object is detected and the calibration is not completed, it will keep flashing.
(The distance changes within 3 seconds, the object has total transmission, all mirror reflection, unstable fixation... all may lead to unsuccessful calibration).
6. If the object is not detected, the calibration has not been completed, and the light will be off after 10 seconds.

Serial number	Baud rate
0	2400
1	4800
2	9600
3	14400
4	19200
5	38400
6	56000
7	57600
8	115200

5th. product selection

Serial number	model	output method
1	XKC-KL200-UART	Serial output
2	XKC-KL200-NPN	Can modify NPN to be normally open or normally closed output
3	XKC-KL200-V	High and low level output

Note: The output mode is that a sensor can only have one output mode.

High and low level signal output: Provide a high and low level signal, which is suitable for small current control high current, control external circuit, MCU signal identification judgment and so on.

Switch output: The signal sent by the switch sensor is a contact signal, which has two states: open and closed. For example, a sensor switch is a common switch sensor. When an object enters the sensing area set by the sensor, the sensor switch is opened (or closed); when the object leaves the sensor set sensing area, the switch is closed (or opened).

NPN output: NPN output is one of the three-wire switch output. When the sensor output is disconnected, it is in a no-voltage floating state and can be connected to the VCC input voltage through a pull-up resistor. When the sensor output is closed, the voltage is 0V, that is, it is turned on to 0V (the negative pole of the power supply). NPN output can directly control the current within 300mA.

UART serial port output: laser switches (except XKC-KL200-V), all with UART configuration function, users can configure related parameters through UART, or specify factory default configuration values. The default configuration values of Xingkechuang are as follows.

Laser switch UART parameter configuration table:

Configuration item	Defaults	instruction
Baud rate	2=9600bps	0-9,2400bps-128000bps (see the baud rate configuration table for details)
Device address	0	0-65534 (65535 is the broadcast address)
Calibration distance value	100	10-2000 (10-2000mm)
Upload mode	1=Manual query	0=auto upload, 1=manual query
Upload interval	1	Value range 1-100 (corresponding to 100ms-10s)
LED mode	0=lights up when there is induction	0=light on when there is induction, 1=off when there is induction, 2=normally off, 3=normally on
Relay mode	0=Start when there is induction	0=start when there is induction, 1=close when there is induction
Line output mode	0=Relay mode	0=relay mode, 1=UART mode

6th. Laser switch LED indicator

Phenomenon	LED indication	Flash parameters (on/off)
Output short circuit	Flash	50ms/50ms
Product failure	Pulse flash	10ms/2S
Calibrating	Slow flashing	1S/1S
Calibration error	Flash	50ms/50ms
Object detected	Chang Liang	
No object detected	Always off	

7th. wiring diagram of various models

1. Simplified schematic diagram of NPN output wiring principle

XKC-KL200-NPN (Switch type) principle and wiring method

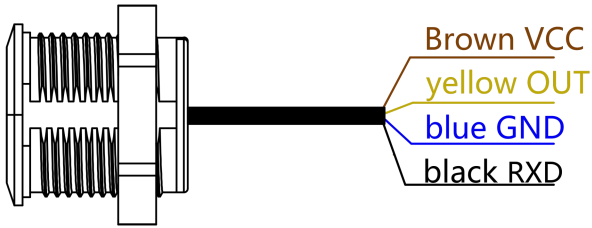

Wiring port definition

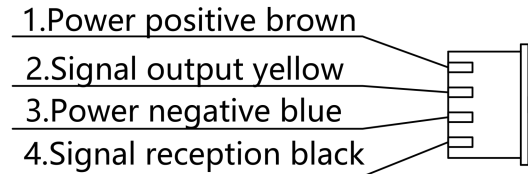

Terminal wiring sequence

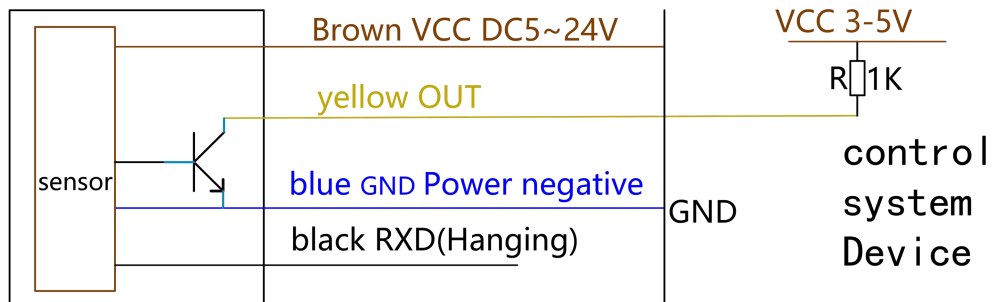

NPN signal output: wiring method to connect to controller or MCU

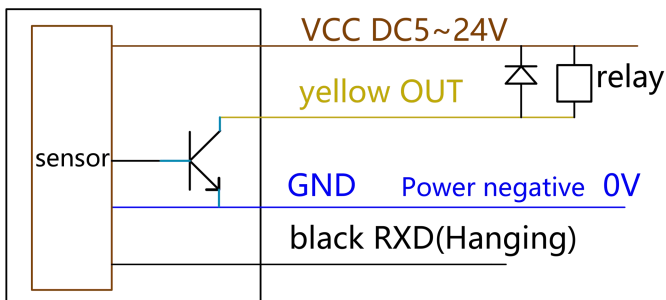

NPN signal output:
Wiring method of connecting relay

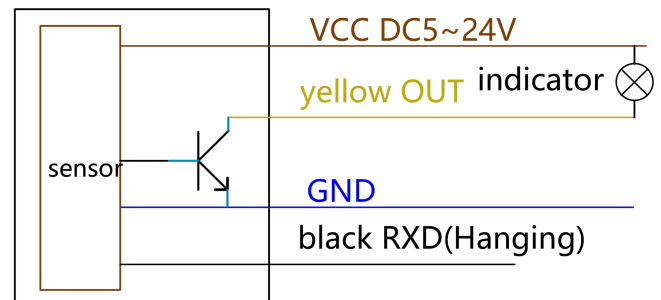

NPN signal output:
Wiring method for connecting LED indicator

NPN output drive small relay (coil current $\leq 300\text{mA}$) working principle:

When liquid is sensed, the transistor is turned on and closed, and the relay is energized and closed;

When no liquid is sensed, the transistor will be cut off and the relay will not be closed when the power is turned off;

2. Simplified schematic diagram of high and low level output wiring principle

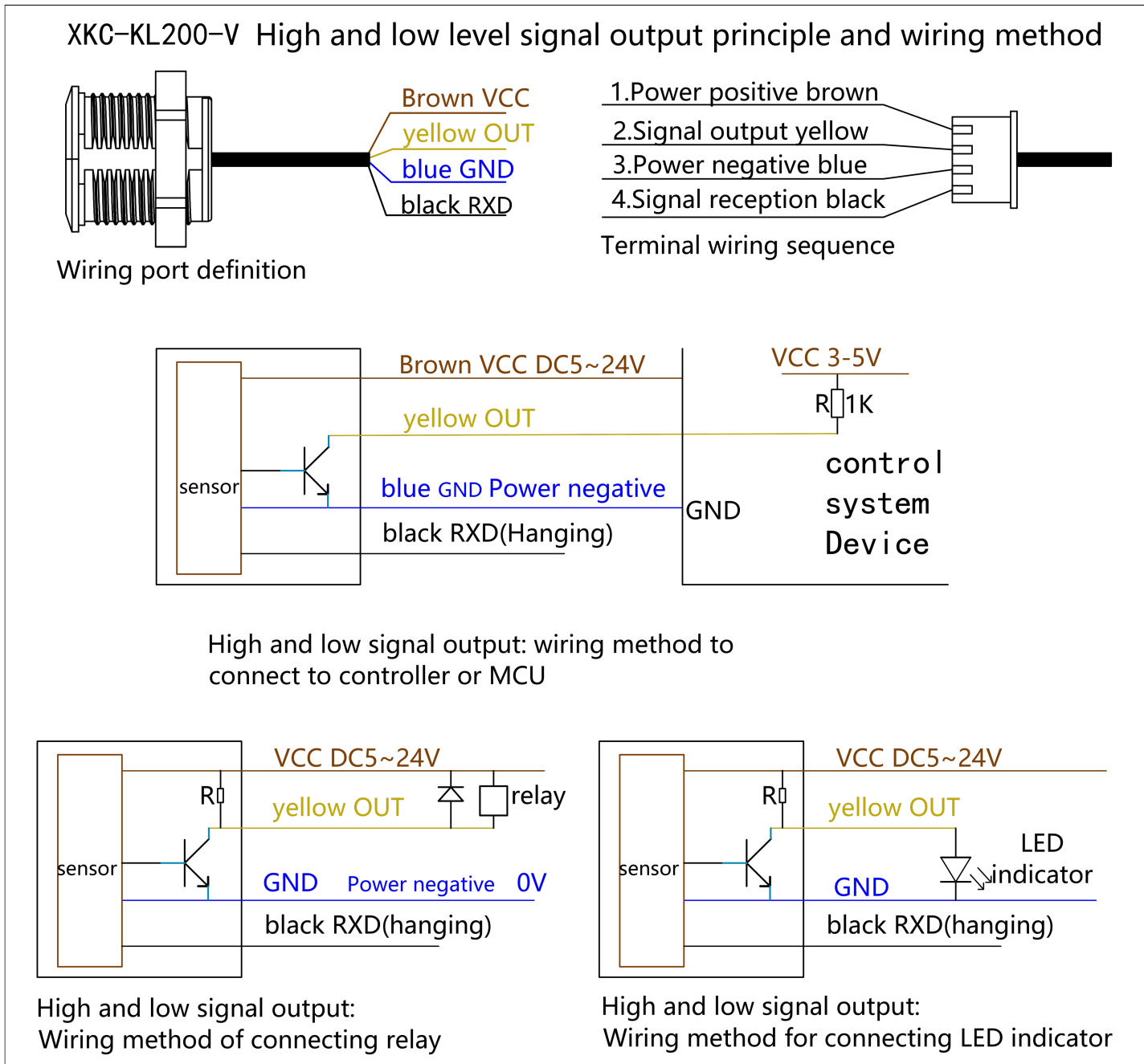

High and low level output drive small relay (coil current $\leq 300\text{mA}$) working principle:

When liquid is sensed, the transistor will cut off and output high level, and the relay will not pull in when the power is turned off;

When no liquid is sensed, the transistor turns on and outputs a low level, and the relay is energized and closed;

3. Simplified schematic diagram of UART serial port output wiring principle

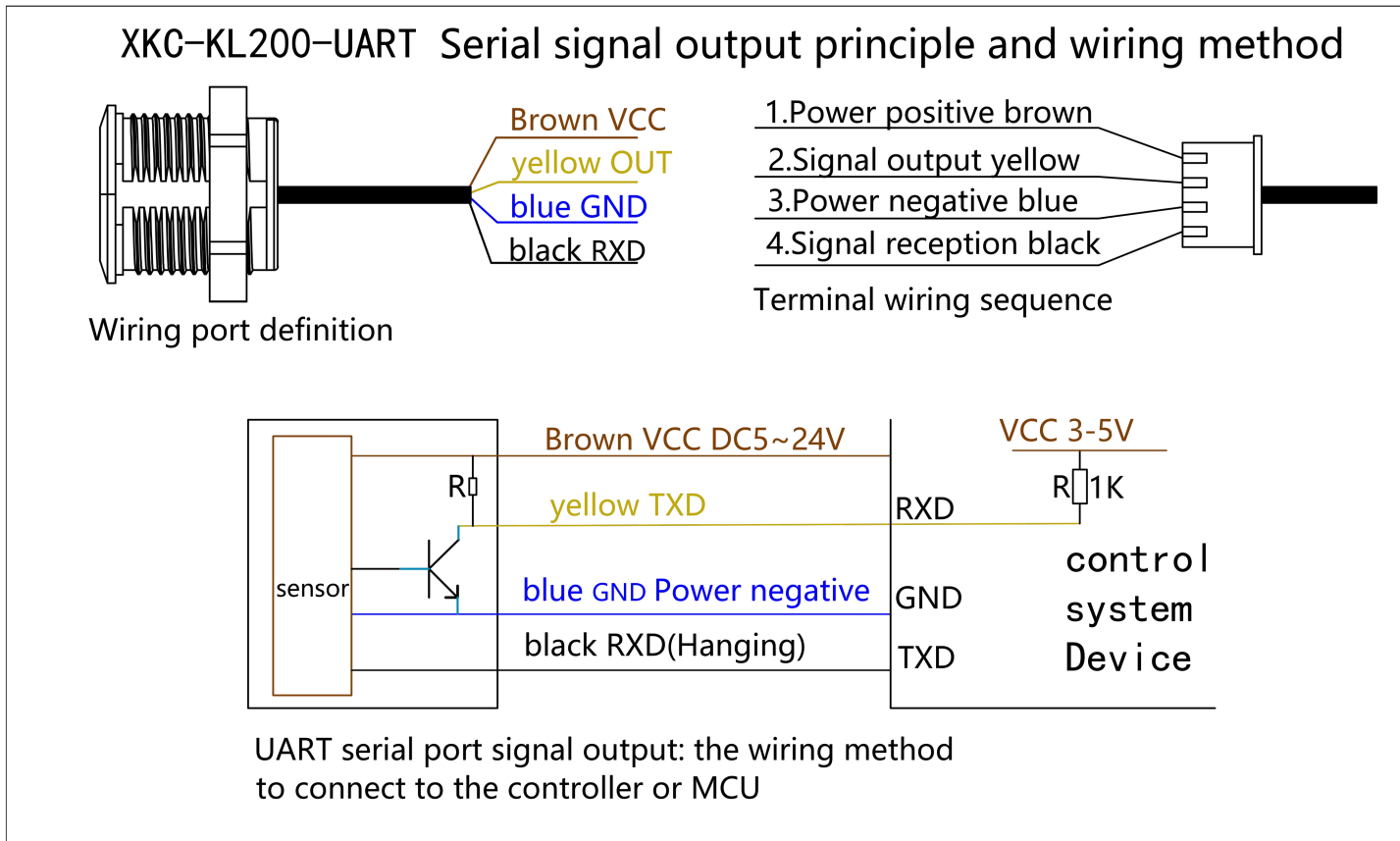

8th. Sensing distance adjustment

1. Place a piece of kraft cardboard about 80cm * 80cm in front of the sensor 200cm (set according to user needs within the range of 10~200cm).
2. The sensor is powered on.
3. Locate the button on the back cover of the sensor, and then press and hold the button.
4. After the indicator light is on for about 1 to 2 seconds, release the button to enter the automatic sensing distance adjustment mode. The sensor and the cardboard should not move, and there should be no obstructions between them. After waiting for about 10 seconds, the indicator light stops flashing and automatically saves the data; it automatically returns to the normal working mode. The pitch adjustment is complete.

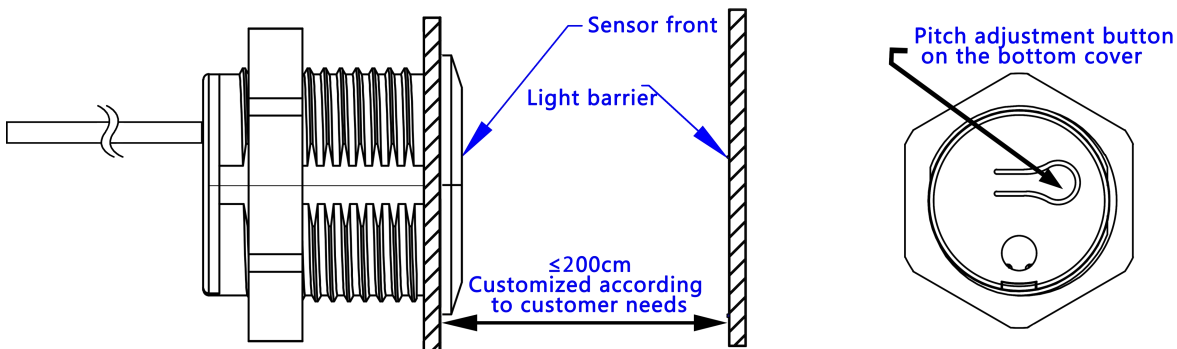

Sensing distance adjustment process

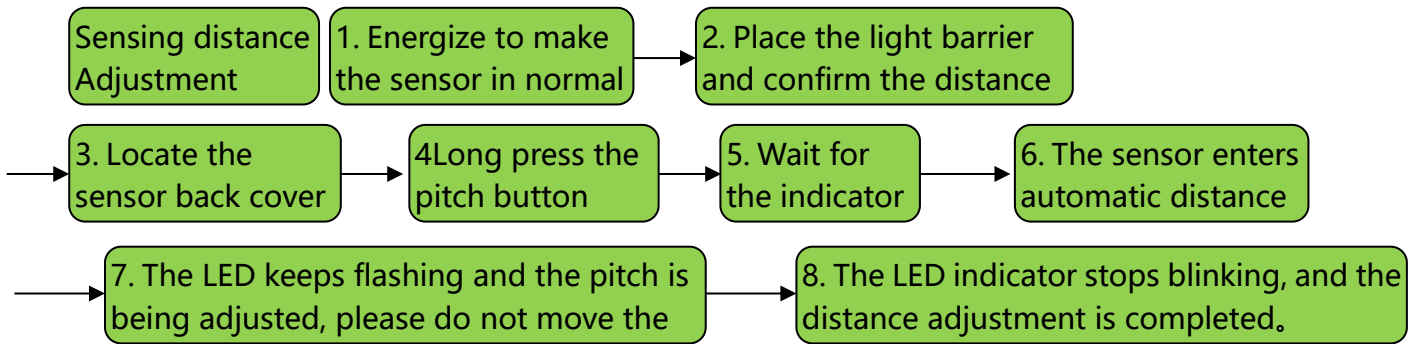

9th. Dimensions and physical objects

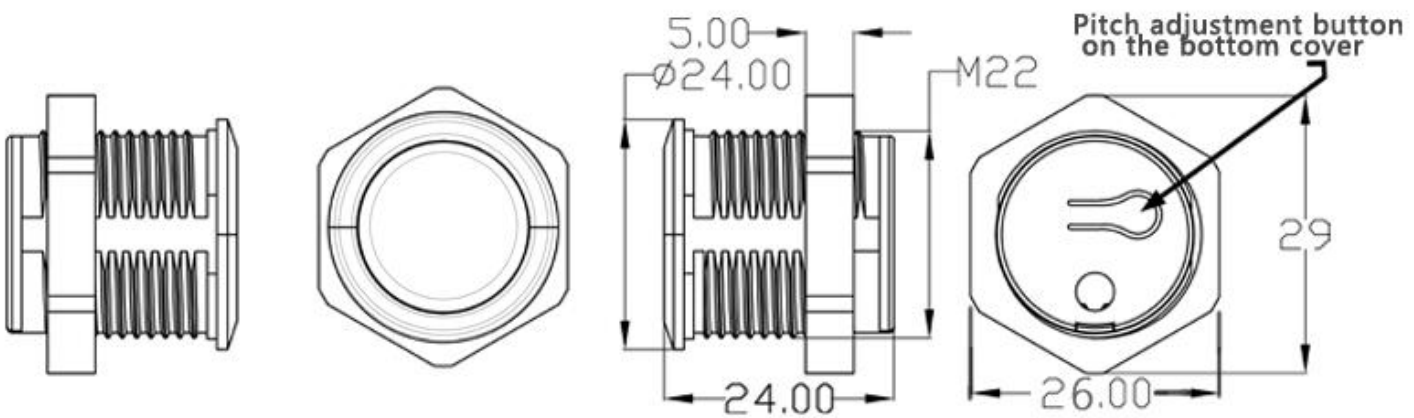

10th. installation method

Open a special-shaped hole on the panel where the sensor needs to be installed, install the sensor

into the hole from the front of the panel, and tighten the nut behind the sensor..

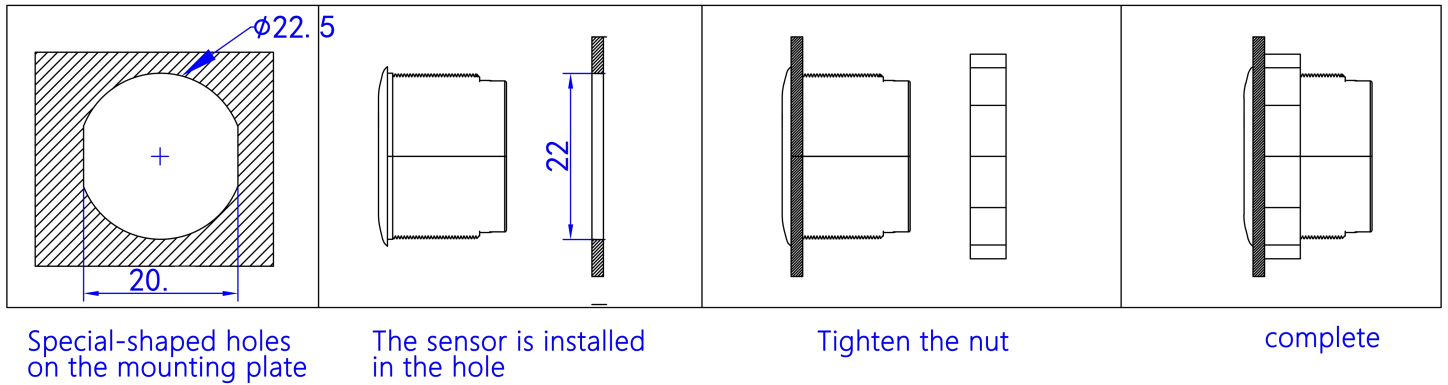

10th. Distance and Object Size Relationship

Minimum diameter range = distance * 0.4666 (mm)

As shown in the figure: when the distance between the sensor and the measured object is 2 meters, Then the size of the object should not be less than 934mm; when the distance between the sensor and the measured object is 1 meters, Then the size of the object should not be lower than 467mm.

Note:

The laser receiving angle is 25 degrees, and the tangent function value of 25 degrees is 0.4666

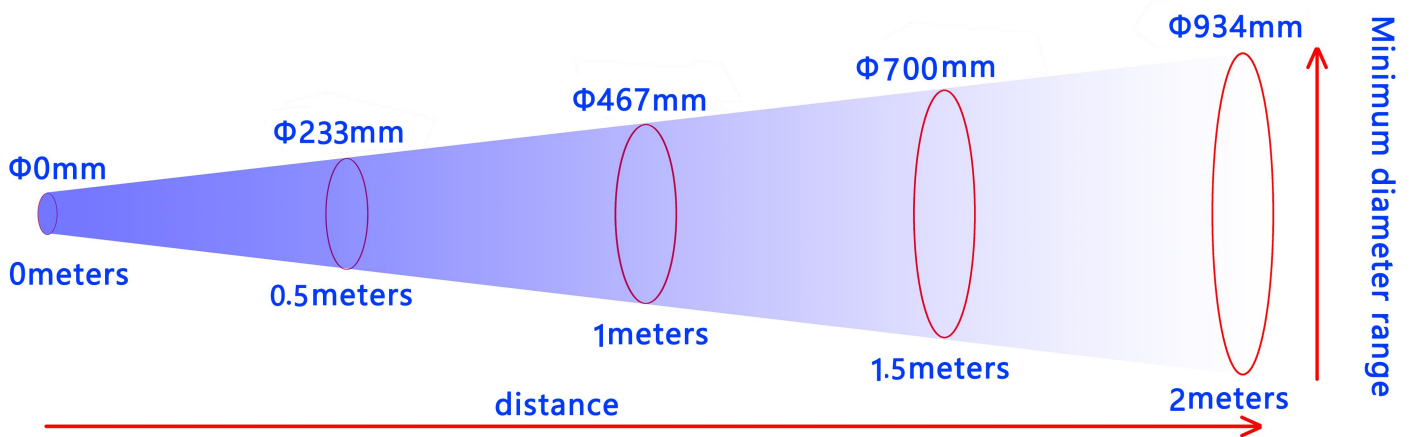

12th. letter of agreement

1.1 The hardware adopts uart.

Brown (VCC), yellow (signal output), blue (GND), black (RXD)

Except XKC-KL200-V, all our laser switch products can be used for UART application, please pay attention to user needs:

1. Power supply 5~24V

2. Connect a pull-up resistor of about 1K between the customer's MCU power supply and the OUTPUT (yellow wire).

1.2 The default configuration of the serial port:

Baud rate: 9600

Data bits: 8

Check Digit: None

Stop bit: 1

1.3 Data format: Hexadecimal:

Data Format	Data Format								
	1	2	3	4	5	6	7	8	9
	Command (B2)		Data length	Address high	Address Low	Data high	Data Low	Answer	Check (XOR)
Send instructions	62	32	09	FF	FF	00	01	00	XOR
General command ACK	62	32	09	00	00	00	00	66	XOR
Read current configuration (Hex) ACK	01	02	03	04		05	6~27	28	29
	62	31	1D	00		00	22 bytes of configuration data	66	XOR
Read current configuration (string)	Configuration string								

1. ASCII command code:
b9 Restore factory settings
b0 configure baud rate
b1 Read current configuration information
b2 Configure 485 address
b3 Read data or upload data automatically
b4 Configure upload data mode
b5 Configure the active upload time interval
b7 Configure LED mode
b8 Configure the relay mode
a0 Configure line mode
a1 Configure response speed
2. Data length: the entire length from the first byte (inclusive) of the command to the check byte (inclusive)
3. Slave address: 0x0000-0xfffe
4. Data: Upstream sensor detection data, configuration data or downstream configuration data
Read current configuration: 22 bytes of configuration data or string (see Read Configuration Instructions for details)
Other instructions: two bytes of data
5. Response: Command is 0x00, response is 0x66
6. Check: 8-bit XOR check

1.4 Function instructions

Restore Factory	Data Format								
	1	2	3	4	5	6	7	8	9
	Command (B2)		Data length	Address high	Address Low	Data high	Data Low	Answer	Check (XOR)
Restore Factory	62	39	09	FF	FF	FF	FF	FE	XOR8
(Xingkechuang default)	62	39	09	FF	FF	FF	FF	FD	XOR8
Successfully returned	62	39	09	00	00	00	00	66	XOR8

The data bit is 0xffff for the factory restoration command, the factory restoration command carries the parameter FE or FD, and the parameter write response bit:

Parameter Description:

FE: Restore the default configuration of Xingkechuang

FD: restore user default configuration

The above command restores the factory with the address of 0000. If you want to restore the factory with any address, you can change the address to FF, FF, as shown below:

62 39 09 FF FF FF FF FE

62 39 09 FF FF FF FF FD

Write address	Data Format								
	1	2	3	4	5	6	7	8	9
	Command (B2)		Data length	Address high	Address Low	Data high	Data Low	Answer	Check (XOR8)
send command	62	32	09	FF	FF	00	01	00	XOR
Successfully returned	62	32	09	00	00	00	00	66	XOR8

Parameter description: 0~65534
The above command changes the 0x0000 address to 0x0001

Modify the baud rate	Data Format								
	1	2	3	4	5	6	7	8	9
	Command (B0)		Data length	Address high	Address Low	Data high	Data Low	Answer	Check (XOR8)

send command	62	30	09	FF	FF	00	02	00	XOR
Successfully returned	62	30	09	00	00	00	00	66	XOR8

Parameter Description:

0 = 2400bps
 1 = 4800bps
 2 = 9600bps
 3 = 14400bps
 4 = 19200bps
 5 = 38400bps
 6 = 56000bps
 7 = 57600bps
 8 = 115200bps
 9 = 128000bps

The above command changes the baud rate to 9600bps

Revise	Data Format								
	1	2	3	4	5	6	7	8	9
	Command (B4)		Data length	Address high	Address Low	Data high	Data Low	Answer	Check (XOR8)
Upload mode	62	34	09	FF	FF	00	01	00	XOR
Successfully returned	62	34	09	00	00	00	00	66	XOR

Parameter Description:

0: Manual query mode
 1: Automatic serialization mode

The above command changes the upload mode to: (automatic upload mode)

Modify automatically	Data Format								
	1	2	3	4	5	6	7	8	9
	Command (B5)		Data length	Address high	Address Low	Data high	Data Low	Answer	Check (XOR8)
Upload interval	62	35	09	FF	FF	00	01	00	XOR
Successfully returned	62	35	09	00	00	00	00	66	XOR

Parameter description: 1-100 (corresponding to 100ms-10s)

The above command will modify the automatic upload interval to 100ms

Revise LED mode	Data Format								
	1	2	3	4	5	6	7	8	9
	Command (B7)		Data length	Address high	Address Low	Data high	Data Low	Answer	Check (XOR8)
send command	62	37	09	FF	FF	00	01	00	XOR
Successfully returned	62	37	09	00	00	00	00	66	XOR
Parameter Description: 0 = lights up when inductive 1 = Turn off when sensing 2 = always off 3 = always on The above command changes the LED mode to: (1 = off when inductive)									

Modify the relay mode	Data format								
	1	2	3	4	5	6	7	8	9
	Command (B8)		Data length	Address high	Address Low	Data high	Data Low	Answer	Check (XOR8)
send command	62	38	09	FF	FF	00	01	00	XOR
Successfully returned	62	38	09	00	00	00	00	66	XOR
Parameter Description: 0 = Start when sensed 1 = Turn off when sensing The above command changes the relay mode to: (1 = close when there is induction)									

Revise Line mode	Data format								
	1	2	3	4	5	6	7	8	9
	Command (a0)		Data length	Address high	Address Low	Data high	Data Low	Answer	Check (XOR8)
send command	61	30	09	FF	FF	00	01	00	XOR

Successfully returned	62	30	09	00	00	00	00	66	XOR
Parameter Description: 0 = Relay mode 1 = UART mode The above command changes the line mode to: (1 = UART mode)									

Revise Trailing mode	Data format								
	1	2	3	4	5	6	7	8	9
	Command (a2)		Data length	Address high	Address Low	Data high	Data Low	Answer	Check (XOR8)
send command	61	32	09	FF	FF	00	01	00	XOR
Successfully returned	62	32	09	00	00	00	00	66	XOR
Parameter description: (see the trailing configuration table for details) 0 = high precision 1 = normal 2 = high stability The above command will modify the trailing mode to: (1 = normal)									

Read Current configuration (String)	Data format								
	1	2	3	4	5	6	7	8	9
	Command (d1)		Data length	Address high	Address Low	Data high	Data Low	Answer	Check (XOR8)
send command	64	31	09	FF	FF	00	00	00	XOR
Successfully returned	Current configuration string								
Parameter Description: Baud rate 0-9, 2400bps-128000bps (see the baud rate configuration table for details) Device address 0-65534 (65535 is the broadcast address) Calibration distance value 30-2000 (30-2000mm) Upload mode 0=automatic upload, 1=manual query Upload interval Value range 1-100 (corresponding to 100ms-10s) LED mode 0=light on when there is induction, 1=off when there is induction, 2=normally off, 3=normally on Relay mode 0=start when there is induction, 1=close when there is induction									

Line output mode 0=relay mode, 1=UART mode

Read current configuration (Hex)	Data format								
	1	2	3	4	5	6	7	8	9
	Command (b1)		Data length	Address high	Address Low	Data high	Data Low	Answer	Check (XOR8)
send command	62	31	09	FF	FF	00	00	00	XOR

Successful return	01	02	03	04	05	06	07	08	09	10	11	12	13	14	15	16	17	18	19	20	21	22	23	24	25	26	27	28	29			
	command			length		Address		Reserve				Reserve	Nocalibration	Baudrate	Device address		Calibration distance value		Upload mode	Upload interval	Reserve		LED mode	Relay mode	Line output mode		Reserve	Reserve	Reserve	Reserve	Answer	Check
	62	31	D0	00								FF	02	00	00	00	64	00	0A				00	00	00						66	XOR

13th. Troubleshooting guide

problem	LED indication	handle
Output short circuit	Flash	Check that the output current is not more than 1A
Product failure	Pulse flash	Contact the agent to return
Mode setting error	Always on Always off Output reverse	Check the LED mode and relay mode. If it is not normal after restoring to the factory, please contact the agent to return it.

14th. Precautions for use

1. The receiving device is interfered by strong light (normal indoor light is not affected, when the light is too strong, the sensitivity will be reduced and the distance will become closer). When installing, try to avoid strong light directly on the probe to make the sensing distance closer and affect the function.
2. When installing, avoid working in an environment with high dust concentration (because high concentration dust is equivalent to sensing objects, which will cause the sensor to malfunction) to

avoid misoperation.

15th.Product warranty terms and instructions

(A) .Warranty service

1. Warranty period maintenance: from the date of purchase, the product host has a one-year free warranty. The company has the right to decide to repair or replace the faulty part. If it is replaced, the replacement part may be a new device or a repair product of the same category, function, and quality. The replaced faulty part belongs to the company; the product Resale and repair do not affect the warranty period. Products that have been repaired or replaced continue to enjoy the original remaining warranty period service. If the warranty period is less than three months after the repair, the repaired or replaced part shall be shipped from the date of delivery Warranty for three months; all products of the company are guaranteed for repair.

2. Loss upon arrival (DOA) replacement: From the day of purchase, you can enjoy a free replacement service within 7 days. Products with the following problems are defined as DOA equipment: the packing and packing list do not match after the first unpacking of the product; some or all of the components cannot be used normally after the first unpacking of the product (surface scratches or other things that do not affect the function of the device) Defects are not included); other hardware failures identified by our company's engineers remotely or locally.

(B). Applicable limitations of warranty

For the following situations, the company does not assume warranty responsibility:

1. The product is out of warranty; the surface of the product is fragile and damaged; the appearance of the product is seriously damaged, installation/use in abnormal environment, unauthorized disassembly and repair/modification, external power supply damage and other abnormal damage;
2. Damage caused by incorrect installation and use of the product by the user not following the requirements of the manual;
3. Damage caused by natural disasters and human negligence (fire, lightning, flooding, impact, etc.).

(C) .Accessories and consumables are not covered by the warranty.

(D) .Non-free warranty service

Within two years of product purchase, for non-warranty product (including components) failures and damages, you can choose paid maintenance services (free labor costs), and we will charge the transportation cost of repairing parts and accessories according to the actual situation.

(E). Ways to obtain warranty service

It is recommended that you contact the dealer who purchased this product to obtain the warranty service. For the warranty, please present a valid warranty card (the dealer's stamp is required to take effect) or the purchase invoice/receipt: if you can't show it, the product's free warranty period 12 months from the product shipment date, and the latest DOA application deadline is 7 days from the product shipment date.

(F). Statement

1. The copyright of this manual belongs to Shenzhen Xingkechuang Technology Co., Ltd. (Xingkechuang) and its authorized licensors. Shenzhen Xingkechuang Technology Co., Ltd. (Xingkechuang) reserves all rights.
2. Without the written permission of the company, no unit or individual may excerpt or copy part or all of the contents of this manual, and shall not spread it in any form.
3. The customer recognizes that the purpose of the design and production of the company's products does not involve use

in products related to life support or other systems or products used in other dangerous activities or environments. Personal injury or death, property or environmental damage due to product failure (collectively referred to as high-risk activities). The company's products are artificially used in high-risk activities, and the company does not guarantee it and is not liable to customers or third parties.

4. Due to product version upgrades or other reasons, the contents of this manual may change. Xingkechuang reserves the right to modify the contents of this manual without any notice or prompt. This manual is only used as a guide. Xingkechuang makes every effort to provide accurate information in this manual. However, Xingkechuang does not guarantee that the contents of the manual are completely free of errors. All statements, information and suggestions in this manual do not constitute any express or Implied guarantee.

5. Not all models are available in all countries/regions

Please keep this manual properly. Before using the product, please read this manual carefully. When using the product, please be sure to operate in accordance with this manual. The company is not responsible for injuries and accidents caused by operations that do not follow this manual.

(G).Environmental protection This product meets the design requirements for environmental protection.The storage, use and disposal should comply with relevant national laws and regulations.Seek to proceed.

16th. Manual version

Version	Release date
V11	2023-11-06